

DATA SHEET

**ELECTROSTATIC DISCHARGE
PROTECTION DEVICES**

INDUSTRIAL / CONSUMER

UBT26A05L03

RoHS compliant & Halogen free



Product specification— March 28, 2021 V.2

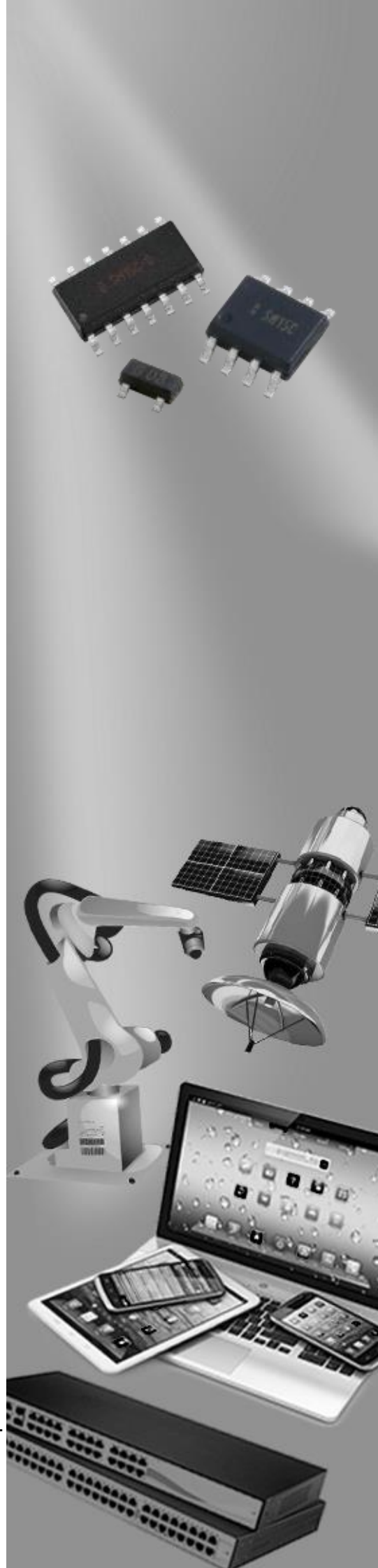

Electrostatic Discharged Protection Devices (ESD) Data Sheet

Description

UBT26A05L03 is designed to protect high speed data interfaces. It has been specifically designed to protect sensitive components which is connected to data and transmission lines from overvoltage caused by electrostatic discharge (ESD), electrical fast transients (EFT), and lightning.



Features

- IEC61000-4-2 ESD 15KV Air, 8KV contact compliance
- SOT23-6L surface mount package
- Protects three data lines
- Working voltage: 5V
- Low leakage current
- Low clamping voltage
- Solid-state silicon avalanche technology
- Lead Free/RoHS compliant
- Solder reflow temperature: Pure Tin-Sn, 260~270°C
- Flammability rating UL 94V-0
- Meets MSL level 1, per J-STD-020
- AEC-Q101 qualified
- Marking: LC62

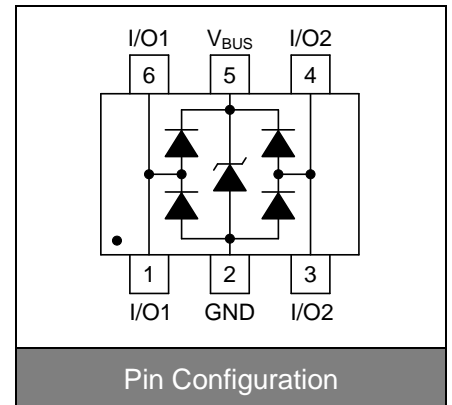

Maximum Ratings

Rating	Symbol	Value	Unit
ESD voltage (Contact discharge)	V_{ESD}	± 8	kV
ESD voltage (Air discharge)		± 15	
Storage & operating temperature range	T_{STG}, T_J	-55~+150	°C

Electrical Characteristics (T_J=25°C)

Parameter	Symbol	Condition	Min.	Typ.	Max.	Unit
Reverse stand-off voltage	V _{RWM}				5.25	V
Reverse breakdown voltage	V _{BR}	I _{BR} =1mA	6			V
Reverse leakage current	I _R	V _R =5.25V Each I/O pin			1	μA
Clamping voltage (tp=8/20μs)	V _C	I _{PP} =1A			12	V
Clamping voltage (tp=8/20μs)	V _C	I _{PP} =5A			17	V
Peak pulse current (tp=8/20μs)	I _{PP}				5	A
Off state junction capacitance	C _J	0Vdc, f=1MHz Between I/O pins and GND		3.5		pF

Typical Characteristics Curves

Figure 1. Power Derating Curve

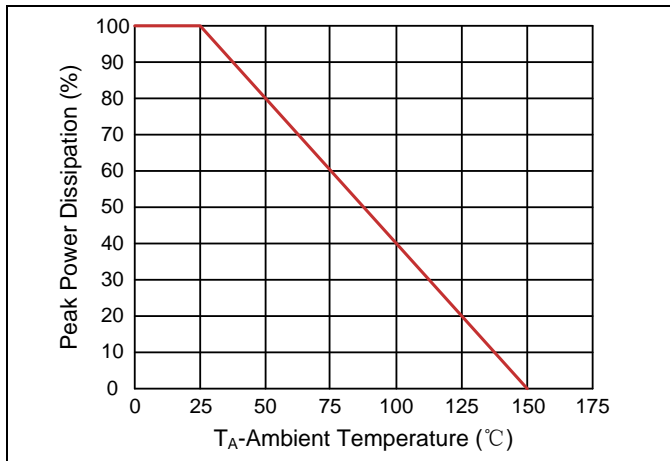

Figure 2. Pulse Waveforms

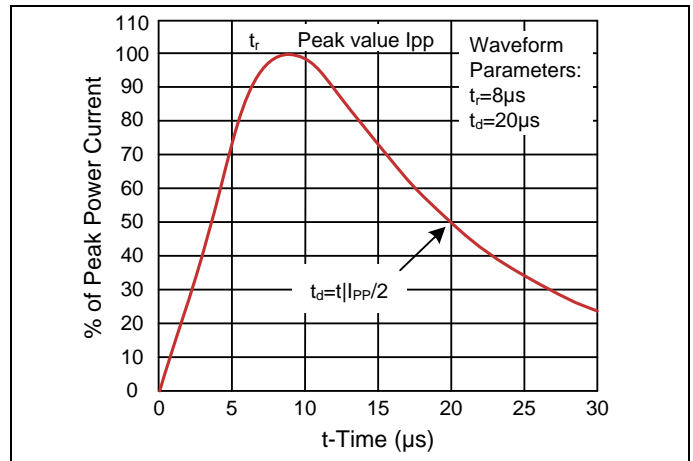

Figure 3. Clamping Voltage vs. Peak Pulse Current

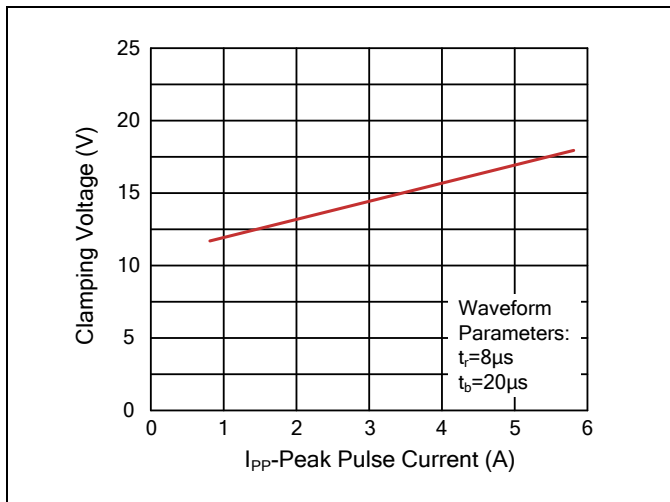
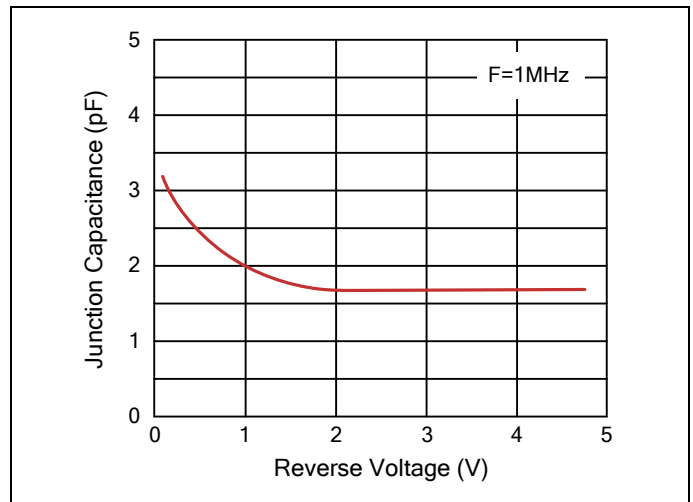
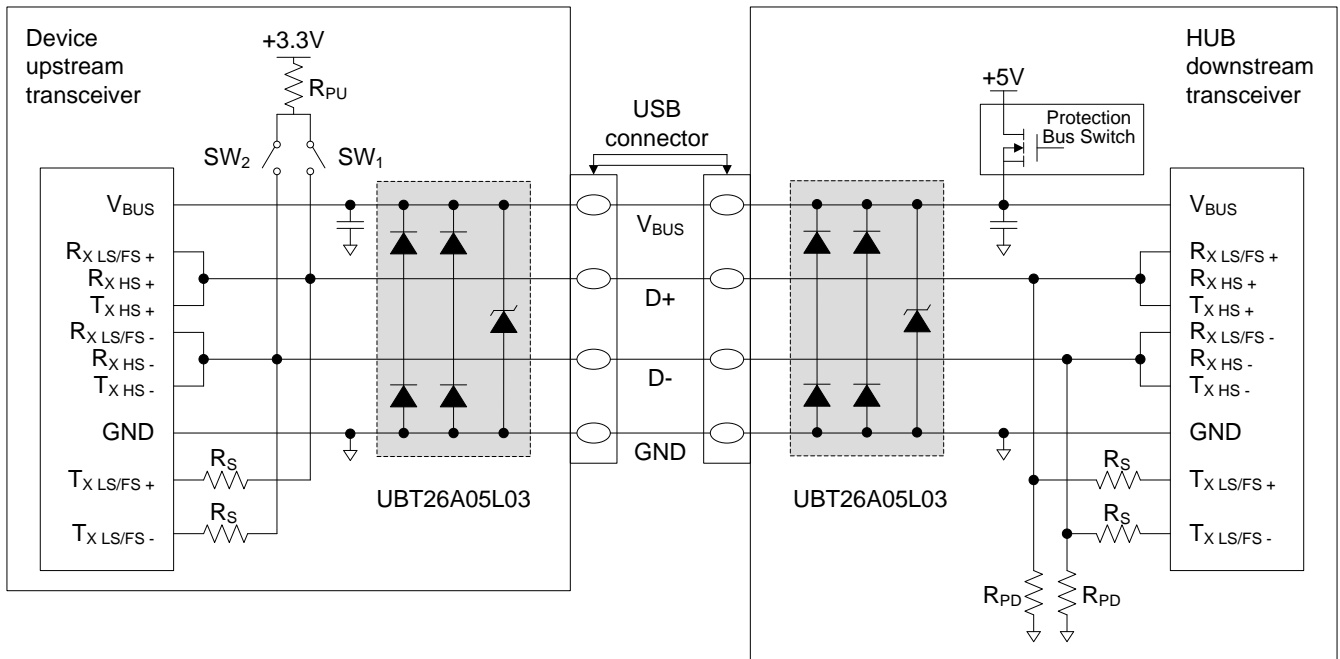

Figure 4. Normalized Capacitance vs. Reverse Voltage



Applications Information

USB 2.0 port application diagram



Mode	SW ₁	SW ₂
Low Speed LS	Open	Closed
Full Speed FS	Closed	Open
High Speed HS	Closed then open	Open

Recommended Soldering Conditions

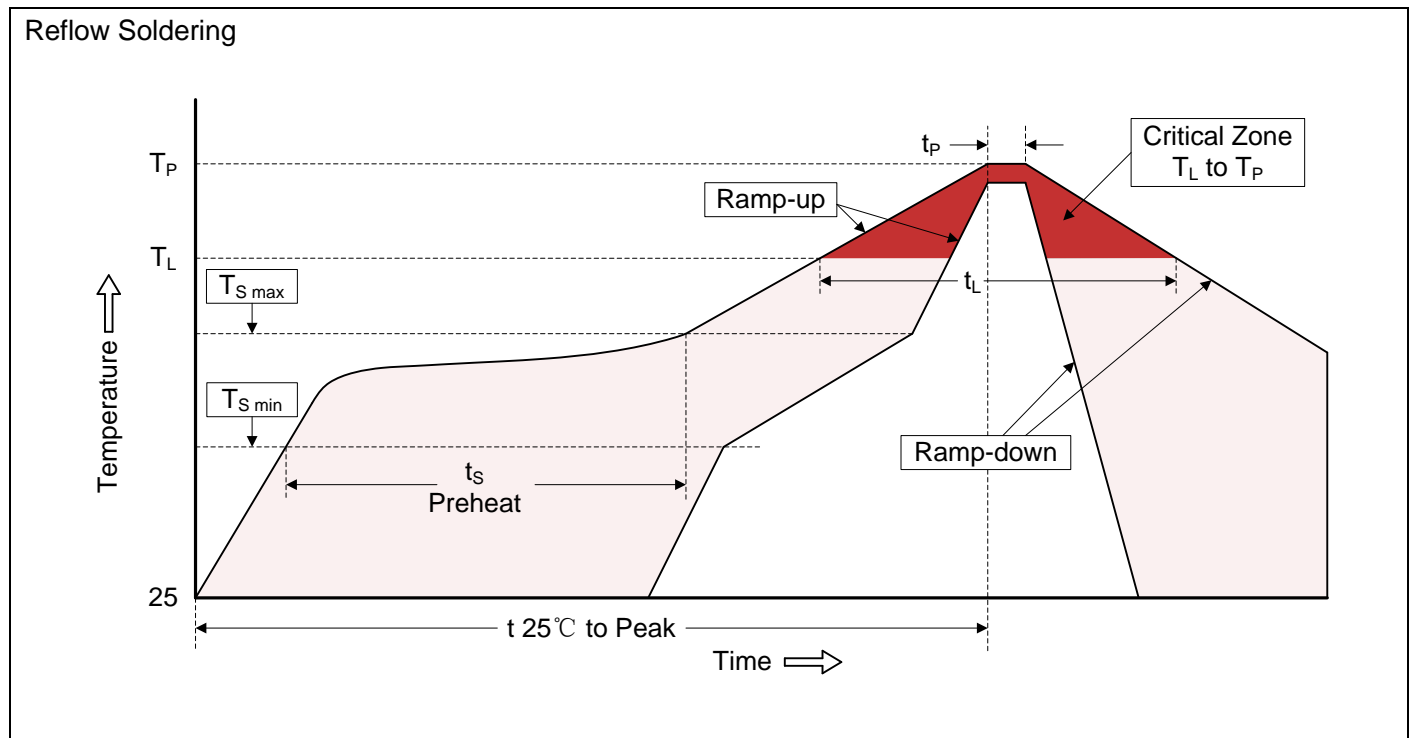

Recommended Conditions

Profile Feature	Pb-Free Assembly
Average ramp-up rate (T_L to T_P)	3°C/second max.
Preheat -Temperature Min ($T_{S\ min}$) -Temperature Max ($T_{S\ max}$) -Time (min to max) (t_s)	150°C 200°C 60-180 seconds
$T_{S\ max}$ to T_L -Ramp-up Rate	3°C/second max.
Time maintained above: -Temperature (T_L) -Time (t_L)	217°C 60-150 seconds
Peak Temperature (T_P)	260°C
Time within 5°C of actual Peak Temperature (t_P)	20-40 seconds
Ramp-down Rate	6°C/second max.
Time 25°C to Peak Temperature	8 minutes max.

Dimensions (SOT23-6L)

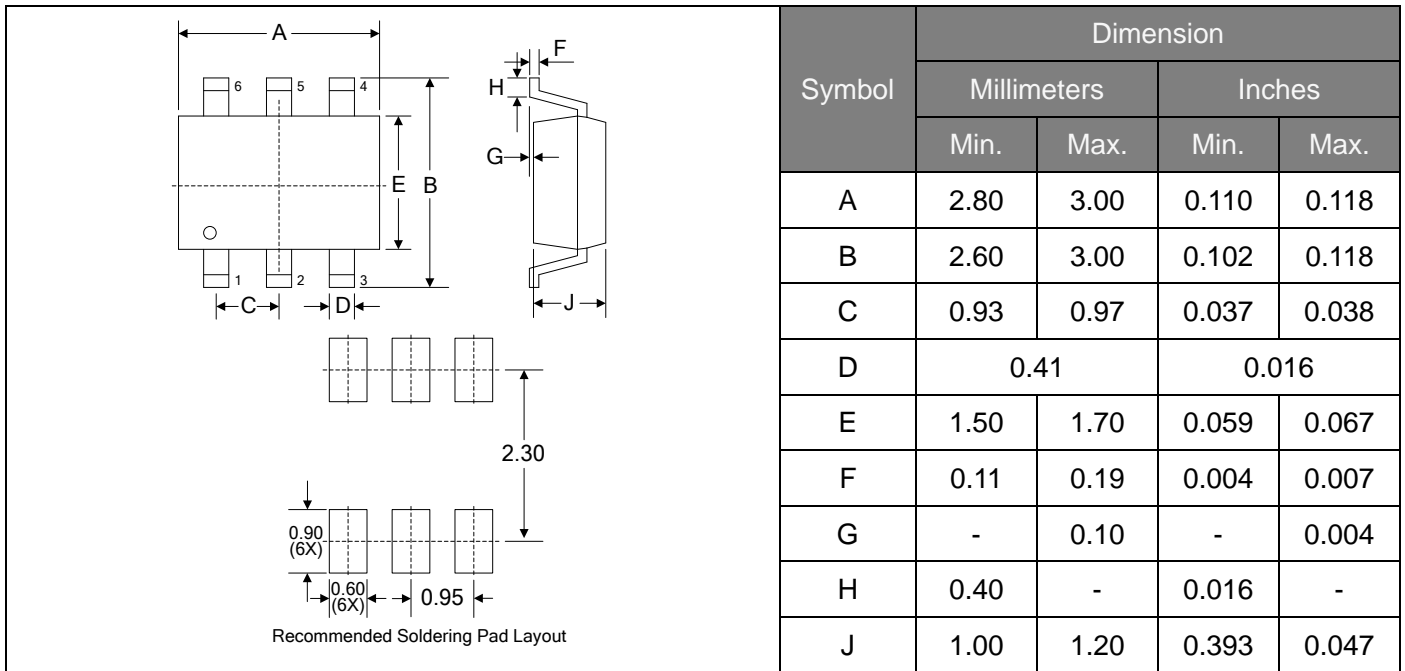

Packaging

